

Enhancement of Coefficient of Performance by Analysis of Flow through Vapour Compression Refrigeration cycle using CFD

Chethan kumar R¹, Dr. C. Badarinath², Mohan Kumar .C.P³, H.V.Harish⁴

P.G Student , Mechanical Department , The oxford college of Engineering , Bangalore , India¹

Head of Department, Mechanical Engineering, The oxford college of Engineering, Bangalore, India²

Head of Refrigeration section , Bamul , Bangalore, India³

Asst. professor , Nitte Meenakshi college of Engineering, Bangalore . India⁴

Abstract: To Improve the Coefficient of Performance, It is to require that and Refrigerating Effect Should Increase and Compressor Work should decrease. Experimental analysis on vapour compression refrigeration (VCR) system with ammonia refrigerant was completed and their results were recorded. The effects of the main parameters of performance analysis such as super heating on the refrigerating effect, power required to run the compressor for various evaporating temperatures, mass flow of refrigerant, percentage increase in COP, coefficient of performance (COP).

The results from vapour compression refrigerant plant was taken where the variables like suction pressure of compressor, delivery pressure of compressor, temperature of evaporator and condenser are noted and coefficient of performance is calculated. The results obtained will be validated through CFD simulation.

Further diffuser has been introduced in between compressor and condenser so that power input to the compressor has been reduced there by enhancing COP The enhancement will be done through CFD simulation; Modeling and meshing will be done in ICEMCFD, analysis in CFX and post results in CFD POST.

Keywords: Evaporator, Diffuser, Enhancement, ICEMCFD, CFX.

I. INTRODUCTION

Refrigeration is the major application area of thermodynamics, in which the heat is transferred to higher temperature region from a lower temperature region. Refrigerators are the devices which produce refrigeration and the refrigerators which operate on the cycles are called refrigeration cycles. Vapour compression refrigeration cycle is the most regularly used refrigeration cycle in which the refrigerant is alternately vaporized and condensed and in the vapor phase it is compressed.

Gas refrigeration cycle is the well-known refrigeration cycle in this cycle refrigerant remains in the gaseous phase throughout. Cascade refrigeration are the other refrigeration cycles discussed in this chapter; absorption refrigeration is the one more refrigeration cycle which is used in which before refrigerant is compressed it is dissolved in liquid. One more refrigeration in which refrigeration is produced by passing the electric current through two dissimilar materials is called as the thermoelectric refrigeration.

1.1 Refrigerators and Heat Pumps

Heat flows from high- temperature medium to a low-temperature medium that is, in the direction of decreasing temperature, we all know this from experience. Without requiring any devices this heat-transfer process occurs in nature. Reverse process doesn't occur by its own. The special devices transfer heat from lower temperature medium to higher temperature medium is called refrigerators. Refrigerants are used as working fluids in the refrigeration cycles, and the refrigerators are cyclic

devices. Fig 1.1a shows the refrigerator schematically. In this Q_L is the magnitude of heat removed at temperature T_L from the refrigerated space, Q_H is the magnitude of heat rejected at temperature T_H to the warm space, the net work input to the refrigerator is $W_{net, in}$ and Q_H and Q_L represents magnitudes and thus are positive quantities

Device Heat pump transfers heat from lower temperature region to higher temperature region. Heat pumps and Refrigerators are basically the same devices; but they dissimilar in their objectives only. Maintaining the refrigerated space at a lower temperature by removing heat from it, is the main objective of a refrigerator. Maintaining the heated space at a high temperature is the objective of a heat pump. This is capable of absorbing heat from a small-temperature medium, such as cold outside air in water or well water, and delivering this heat to a warmer medium such as a house (Fig1.1b).

Performance of heat pumps and refrigerators are expressed in terms of the **coefficient of performance (COP)**, defined as -

$$COP_R = \frac{\text{Desired output}}{\text{Required input}} = \frac{\text{Cooling effect}}{\text{Work input}} = \frac{Q_L}{W_{net,in}} \quad (1-1)$$

$$COP_{HP} = \frac{\text{Desired output}}{\text{Required input}} = \frac{\text{Heating effect}}{\text{Work input}} = \frac{Q_H}{W_{net,in}} \quad (1-2)$$

Above relations can also be expressed in the rate form by replacing the quantities Q_H , Q_L and $W_{net,in}$ by \dot{Q}_H , \dot{Q}_L , and $\dot{W}_{net,in}$ respectively. Note that both COP_{HP} and COP_R can be greater than 1. The comparison of equations 1-1 and 1-2 reveals that

$$COP_{HP} = COP_R + 1 \quad (1-3)$$

The rate of heat removal from the refrigerated space that is the refrigeration system cooling capacity is actually represented in terms of tons of refrigeration. Refrigeration system capacity can freeze 1 ton (2000lbm) of liquid water at 0°C (32°F) into ice at 0°C in 24h is said to be 1 ton. 1 ton of refrigeration is equivalent to 200 Btu/min or 211kj/min. The typical 200-m² residence cooling load is in the 3-ton (10-kW) range.

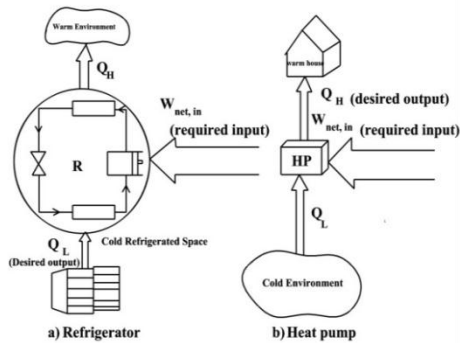

Fig 1.1 a) Refrigerator Fig 1.1 b) Heat pump

1.2 The ideal vapor- compression Refrigeration cycle

Many of the impracticalities related with the reversed Carnot cycle can be removed by completely vaporizing the refrigerant before it is compressed and by replacing the turbine with a throttling devices, such as capillary tube or an expansion valve. The cycle that results is known as the **ideal vapor- compression refrigeration cycle**, and it is shown schematically and on T-s diagram in Fig 1.2. The vapor-compression refrigeration cycle is the most broadly used cycle for heat pumps, air conditioning systems, and refrigerators. It consists of four processes:

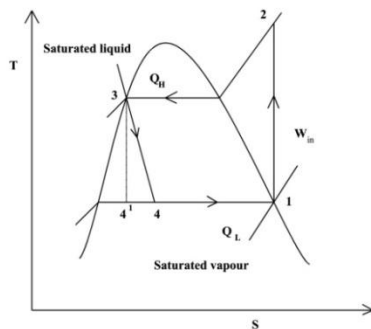

Fig 1.2 T-s Diagram For The Ideal Vapour Compression Refrigeration Cycle

Process 1-2 represents isentropic compression in a compressor

Process 2-3 represents Constant- pressure heat rejection in a condenser

Process 3-4 represents Throttling in an expansion device

Process 4-1 represents Constant -pressure heat absorption in an evaporator

In the ideal vapour-compression refrigeration cycle, the refrigerant enters as a saturated vapour to the compressor at stage 1 and is compressed isentropically to the condenser pressure. During this isentropic compression

process the refrigerant temperature increases to well above the temperature of the surrounding medium. Refrigerant after leaving the compressor enters in to the condenser as superheated vapor at state 2 and leaves the condenser as saturated liquid at state 3 by rejecting the heat to the surroundings. At the state 3, the temperature of the refrigerant is still above the temperature of the surroundings.

At state 3 the saturated liquid refrigerant is throttled to the pressure of the evaporator by passing it through capillary tube or an expansion valve. During the throttling process the refrigerant temperature drops below the temperature of the refrigerated space. At state 4, the refrigerant enters the evaporator as a low-quality saturated mixture (mixture of saturated liquid and saturated vapour), and by absorbing heat from the refrigerated space it completely evaporates. For completing the cycle the refrigerant leaves as saturated vapor from the evaporator and again enters the compressor.

P-h diagram is frequently used in the analysis of vapor-compression refrigeration cycles, as shown in Fig1.3. Three of the four processes appear as straight lines on this diagram. And the heat transfer in the evaporator and the condenser is relative to the lengths of the equivalent process curves.

The evaporator and the condenser do not involve any work, and the compressor can be estimated as adiabatic. Then the COP's of heat pumps and refrigerators working on the vapour- compression refrigeration cycle can be expressed as

$$COP_R = \frac{q_L}{W_{net,in}} = \frac{h_1 - h_4}{h_2 - h_1} \quad (1-7)$$

And

$$COP_{HP} = \frac{q_H}{W_{net,in}} = \frac{h_2 - h_3}{h_2 - h_1} \quad (1-8)$$

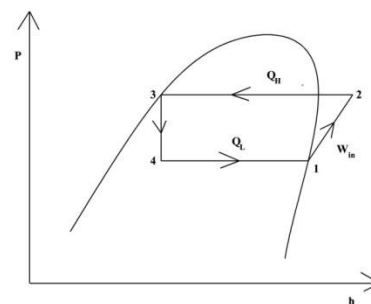

Fig 1.3 P-H Diagram of An Ideal Vapour Compression Refrigeration Cycle

1.3 Actual Vapour Compression Cycle

Actual vapour compression cycle is different from the theoretical cycle in a number of ways because of the following reasons:

1. Regularly the liquid refrigerant is sub-cooled before it is allowed to enter the expansion valve, and generally the gas leaving the evaporator is super heated a few degrees before it goes into the compressor. as a result of expansion control used or through a pickup heat in the suction line between the evaporator and compressor super heating takes place.

2. Compression, although usually assumed to be isentropic, may actually proved to be neither isentropic nor polytropic.
3. Both the discharge valves and compressor suction are actuated by the difference in pressure and the process requires discharge pressure to be above that of condenser and the actual suction pressure inside the compressor to be to some extent below that of the evaporator .
4. Although isentropic compression assumes no transfer of heat between the cylinder walls and the refrigerant, actually the walls of the cylinder are colder than the compressed gases discharged to the condenser, and hotter than the incoming gases from the evaporator.
5. By locating the evaporator and condenser at different elevations, drop in pressure occurs in liquid line piping and long suction and any vertical differences in head created.

Fig 1.4 shows the actual vapor compression cycle on TS diagram. He various processes are discussed as follows:

Process 1-2-3 represents refrigerant passing through the evaporator, latent heat of vaporization is indicated by the line 1-2 and the gain of superheat before entrance to compressor is indicated by 2-3, Processes 1-2 and 2-3 approach very strongly to the constant pressure conditions.

Process 3-4-5-6-7-8 passage of the vapor refrigerant from the entrance to the discharge of the compressor is represented by this path. The throttling action is represented by the path 3-4 that occurs during passage through the suction valves and throttling during passage through exhaust valves is represented by path 7-8. Both of these actions are helped by an entropy increase and a small slump in temperature.

Path 5-6 represents the Compression of the refrigerant which is actually neither polytropic nor isentropic. The heat transfer indicated by path 4-5 and 6-7 occurs essentially at constant pressure. **Process 8-9-10-11**, the passage of refrigerant is represented by this process through the condenser with removal of superheat is indicated by 8-9 , 9-10 the removal of latent heat, and sub cooling or heat of liquid is represented by path 10-11.

Process 11-1, passage of refrigerant is represented by this process through the expansion valve, both practically and theoretically an irreversible adiabatic path.

1.3.1 Effect of Super Heating

The effect of superheating is to increase the refrigerating effect as seen from the fig1.5, but increases in quantity of work used to attain the upper pressure limit is increased by increasing in the refrigerating effect. Since the raise in refrigerating effect is a smaller amount as compared to increase in work, therefore the COP is low for overall effect of superheating.

1.3.2 Effect of Sub-Cooling Of Liquid

‘sub-cooling’ is the method of cooling the liquid refrigerant less than the condensing temperature for a given pressure. 4-4' shows the process of sub-cooling in fig1.6. It is clear from the figure refrigerating effect is increased by effect of sub cooling. Increase in COP is resulted by sub cooling. Provided that no further energy

has to be spent in order to attain the extra cold coolant required.

The under-cooling or sub cooling may be done by any of the following methods:

1. Inserting a special coil between the condenser and the expansion valve.
2. Circulating greater quantity of cooling water through the condenser.
3. Using water cooler than main circulating water.

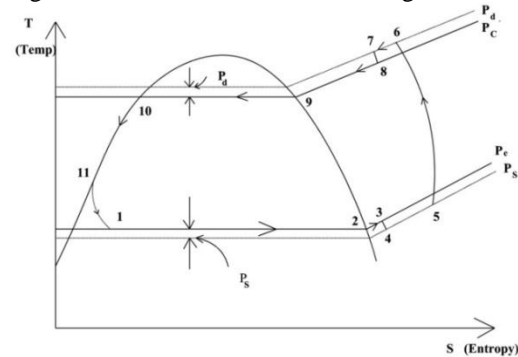

Fig 1.4 Actual Vapour Compression Cycle (T-s diagram)

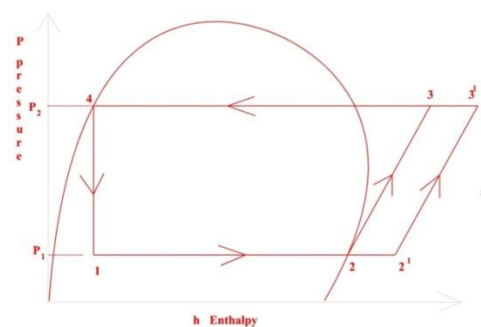

Fig 1.5 Effect of Super Heating

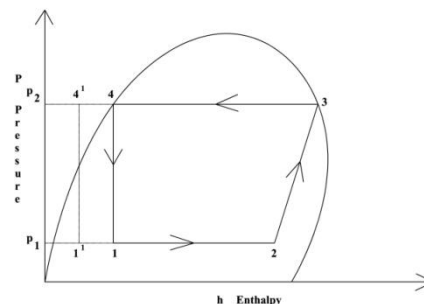

Fig 1.6 Effect of Sub cooling

II. METHODOLOGY

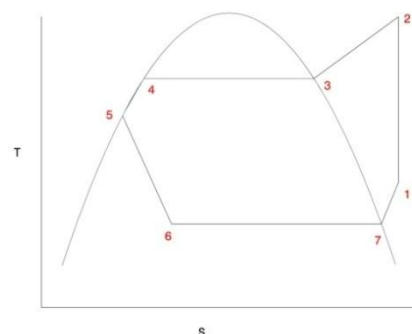

Fig 2.1 Actual Vapour Compression Cycle (T-S Diagram)

$h_4 = h_f$ at condenser temperature
 $h_5 = h_4 - c_p (T_4 - T_5)$
 $h_7 = h_g$ at evaporator temperature
 $h_1 = h_7 + c_p (T_1 - T_7)$
 h_3 is h_g at condenser temperature
 $h_2 = h_3 + c_p (T_2 - T_4)$

$$\text{COP} = \frac{\text{Refrigeration effect}}{\text{work input}} = (h_5 - h_6) / (h_2 - h_1)$$
 $m_r = \text{refrigeration capacity} / \text{refrigeration effect} \text{ kg/s}$
 Refrigeration capacity = $m (h_1 - h_6)$
 $Q = m_R c_p dt$ Watts
 Compressor power = $m (h_2 - h_1)$ kW
 Result taken from BAMUL refrigeration plant is validated through CFD
 Further Diffuser has been used to decrease power input to the compressor which will enhance COP.
 Diffuser length = $(d_1 + d_2) / \tan \theta$
 Different d/l ratio of 0.5 and 0.6 for divergence angle of 15° has been carried so as to decrease power input of the compressor which will result in increasing cop
 Modeling and meshing done in ICEM-CFD, analysis in CFX and post result in CFD POST.

III. EXPERIMENTAL DETAILS



Fig 3.1 Experimental Set Up Of BAMUL Plant



Fig 3.2 Refrigeration Unit of BAMUL

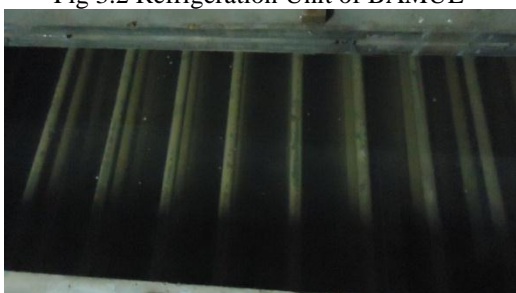

Fig 3.3 Evaporator Coil

Calculations

3.1 Results Calculated From BAMUL Observations

$h_4 = h_f$ at 10.5 bar = $(10.5 \times 10^5) / (10^3) = 1050 \text{ kpa} = 468 \text{ kJ/kg}$
 $h_5 = h_4 - c_p (T_4 - T_5) = h_6$
 $h_5 = 468 - 2.8(29 - 23)$
 $h_5 = 451.2 \text{ kJ/kg} = h_6$
 $h_7 = h_g$ at 3 bar = 300 kpa = 1594 kJ/kg
 $h_1 = h_7 + c_p (T_1 - T_7)$
 $h_1 = 1594 + 2.8(-0.2 - (-0.9))$
 $h_1 = 1595.96 \text{ kJ/kg}$
 h_3 is h_g at 10.5 bar = 1050 kpa = 1627.3 kJ/kg
 $h_2 = h_3 + c_p (T_2 - T_4)$
 $h_2 = 1627.3 + 2.8(73 - 29)$
 $h_2 = 1750.5 \text{ kJ/kg}$

$$\text{COP} = \frac{\text{Refrigeration effect}}{\text{work input}} = (h_1 - h_6) / (h_2 - h_1)$$

$$= \frac{1595.96 - 451.2}{1750.5 - 1595.96}$$

$$\text{COP} = 7.40$$
 $m_R = (260 \times 3.5) / (h_5 - h_6) = (580 \times 3.5) / (1595.96 - 451.2)$
 $m_R = 0.7950 \text{ kJ/kg}$
 $Q = m_{\text{Refrigerant}} \times c_p \times 0.7$
 $Q = 0.7950 \times 2.8 \times 0.7 \times 1000$
 $Q = 1558.2 \text{ WATTS}$
 $L = (\pi \times 60) / 2 = 94.2477 / 1000 = 0.09424 \times 4$
 $L = 0.376 + 15$
 $L = 15.376 \text{ m}$
 $q = \frac{Q}{A} = \frac{1558.2}{\pi \times 0.02 \times 15.376}$
 $q = 1613 \text{ W/m}^2$

Now observations of BAMUL will be validated through CFD

3.2 Evaporator Flow Analysis

Modeling and meshing of evaporator coil
Modeling and meshing done in ICEM-CFD

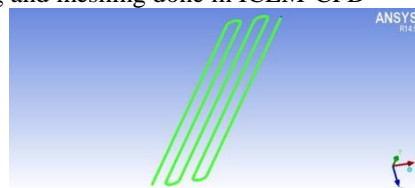

Fig 3.4 Evaporator Modeling

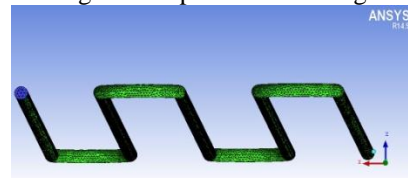

Fig 3.5 Meshing

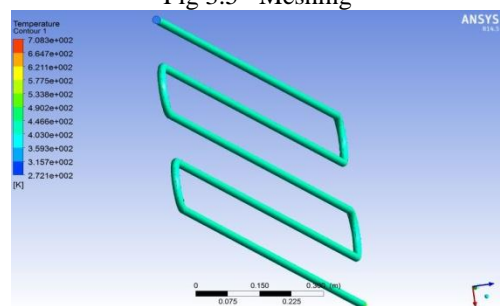

Fig 3.6 Temperature Contour 1

It is seen from the figure that temperature is 272.1K which clearly validates the result taken from BAMUL.

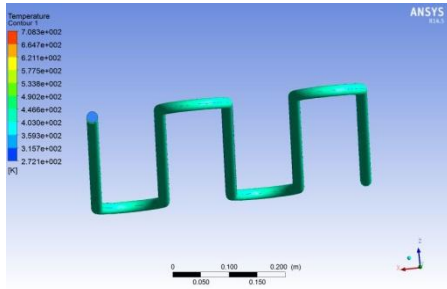

Fig 3.7 Temperature Contour 1

It is seen from the figure that outlet temperature is 272.8k which clearly validates the result taken from BAMUL.

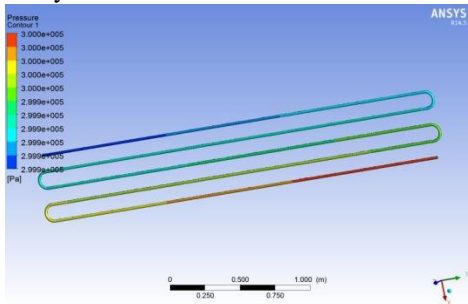

Fig 3.8 Pressure Contour

It is seen from the figure that pressure plane pressure is constant which indicates that constant pressure process is taking place.

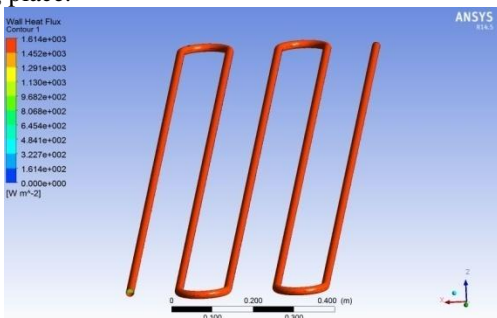

Fig3.9 Wall Heat Flux Contour 1

It is seen from the figure heat flux is 1613w/m²k which clearly validates calculated value of heat flux.

IV. RESULTS AND DISCUSSIONS

Enhancement of COP by Providing Diffuser between Compressor and Condenser with Divergence Angle of Diffuser 15°

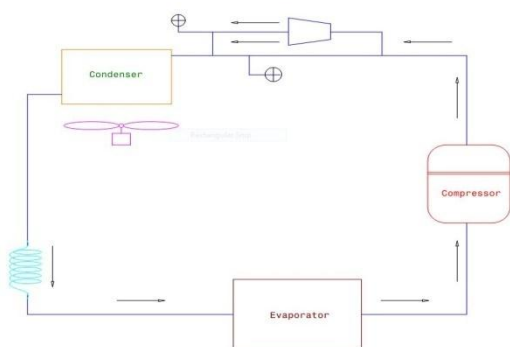

Fig 3.10 Vapour Compression Refrigeration Cycle Along With Diffuser Block Diagram

4.1 GEOMETRY OF DIFFUSER (D/L=0.5)

- Inner dia=20 mm
- Outer dia=41.42mm
- Angle of divergence=15°
- Length of diffuser=40mm
- Diffuser angle selected on the basis of reference paper
- Inlet dia on the basis of BAMUL condenser inlet pipe dia
- length of the diffuser selected on the basis of d/l ratio 0.5 and 0.6

RESULTS OF CFD SIMULATION D/L=0.5

Boundary conditions

Inlet conditins

Inlet pressure = 10.5 bar

Inlet temperature = 73°C

Outlet conditions

$\dot{m} = 0.7950 \text{ kg/s}$

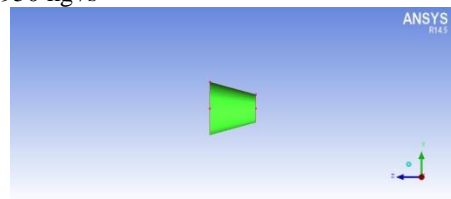

Fig 4.1 Diffuser Modeling

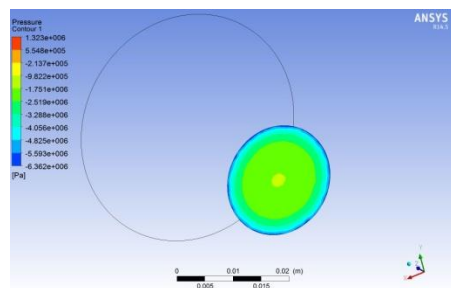

Fig 4.2 Inlet Pressure Contour

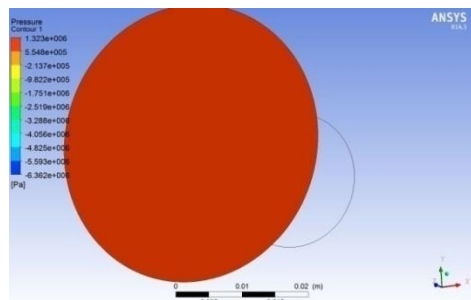

Fig 4.3 Outlet Pressure contour

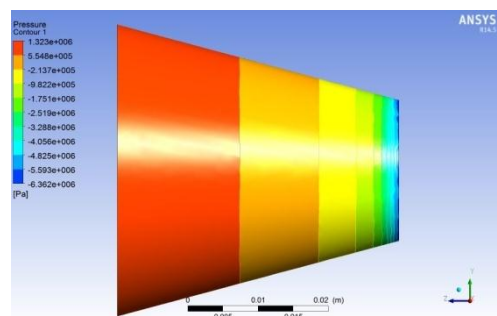

Fig 4.4 Pressure Contour

From above results it has been observed that although outlet pressure has increased the inlet pressure boundary condition that is the pressure given has not been obtained hence geometry selected is not proper. Hence for further analysis d/l ratio of 0.6 has been selected.

4.2 GEOMETRY OF DIFFUSER (D/L=0.6)

- Inner dia=20 mm
- Outer dia=38mm
- Angle of divergence=15°
- Length of diffuser=33.5mm

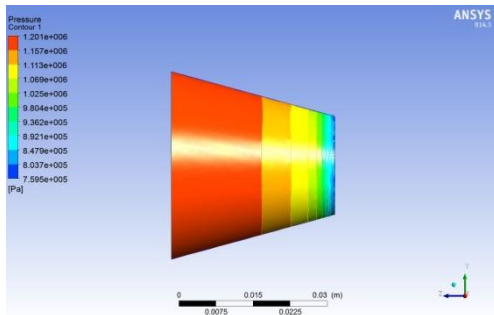

Fig 4.5 Pressure contour

From above results it has been observed that outlet pressure has increased, the inlet pressure boundary condition that is the pressure given has been obtained

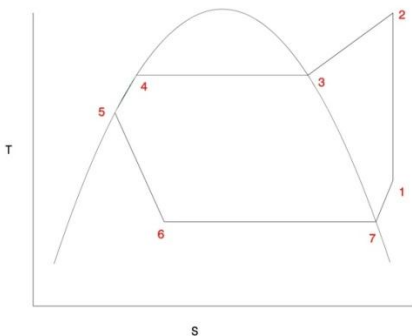

Fig 4.6 Actual Vapour Compression Cycle (T-S diagram)

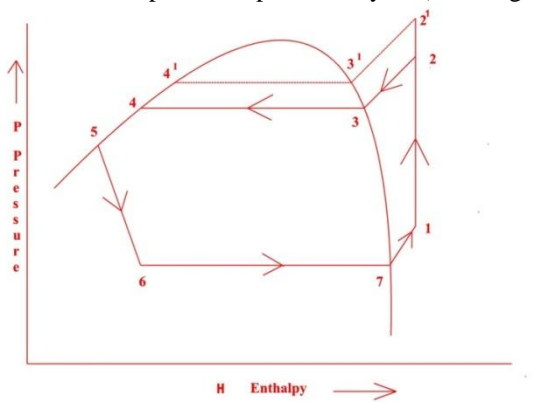

Fig 4.7 Pressure Enthalpy chart

When diffuser added pressure from 2 to 2¹ i.e. from 10.5 bar to 12 bar. But, if diffuser is not there compressor take additional power input to reach 12 bar.

WITHOUT DIFFUSER

Therefore Compressor input = h₂¹ - h₁
Refrigeration effect = h₁ - h₆

To find COP

At 12 bar T_{sat} = 31°C
At 12 bar= 1200 kpa, h_g=1629.8 kJ/kg =h₃¹
T_{sat}=31°C=T₃¹
h₂¹= h₃¹ - c_p(T₂¹-T₃¹)
Diffuser from the compressor at 12 bar is T₂¹ =77.5°C
h₂¹=1629.8 + 2.8(77.5 - 31)
h₂¹=1760 kJ/kg
COP without diffuser is = (net refrigerating effect)/(work done) = (h₁ - h₆) / (h₂¹ - h₁) COP=(1595.96 - 451.2)/(1760 - 1595.96)
COP = 6.928
Power = ṁ(h₂¹ - h₁) = 0.7950(1760 - 1595.96)
Power = 130.4118 kW

WITH DIFFUSER

h₄ = h_f at 10.5 bar = (10.5 × 10⁵) / (10³) = 1050 kpa = 468 kJ/kg
h₅ = h₄ - c_p(T₄ - T₅) = h₆
h₅ = 468 - 2.8(29 - 23)
h₅ = 451.2 kJ/kg = h₆
h₇ = h_g at 3 bar = 300 kpa = 1594 kJ/kg
h₁ = h₇ + c_p(T₁ - T₇)
h₁ = 1594 + 2.8(-0.2 - (-0.9))
h₁ = 1595.96 kJ/kg
h₃ is h_g at 10.5 bar = 1050 kpa = 1627.3 kJ/kg
h₂ = h₃ + c_p(T₂ - T₄)
h₂ = 1627.3 + 2.8(73 - 29)
h₂ = 1750.5 kJ/kg
COP = $\frac{\text{Refrigeration effect}}{\text{workinput}} = \frac{(h_1 - h_6)}{(h_2 - h_1)}$
= $\frac{1595.96 - 451.2}{1750.5 - 1595.96}$
COP = 7.40
Power = ṁ(h₂ - h₁) = 0.7950(1750 - 1595.96)
Power = 122.4618 kW
Percentage of increase in COP when diffuser added
(7.40 - 6.978) / (6.978) × 100
= 0.0570 × 100
= 5.70%

V. CONCLUSION

Sl no	Refrigeration Effect Without Diffuser kJ/kg	Compressor Input Without Diffuser kJ/kg	Refrigeration Effect With Diffuser kJ/kg	Compressor Input With Diffuser kJ/kg
1	1144.76	164.04	1146.76	154.54

Table 4.1 Results

Sl No	Power Input To Compressor Without Diffuser kW	Power Input To Compressor With Diffuser kW	Cop Without Diffuser	Cop With Diffuser	% Of enhancement of cop
1	130.41	122.461	6.928	7.40	5.70

Table 4.2 Results

Graph Compressor input v/s COP

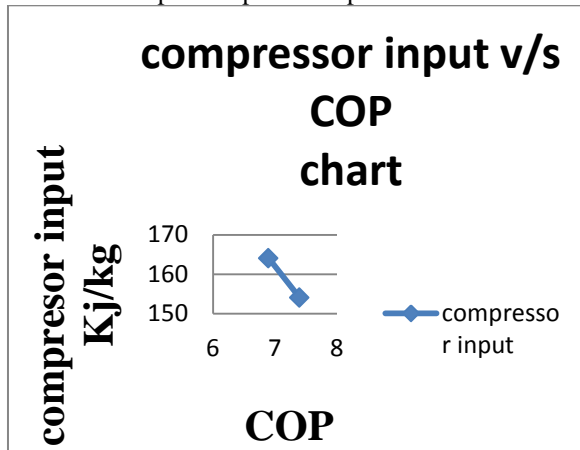

ACKNOWLEDGEMENT

This project wouldn't have been successful without the help of many people. Many people contributed their knowledge and time to make this project successful one. I would like to extend my gratitude to all of them with the help of this acknowledgement. Without the effort of all these people I would not have completed this project successfully.

I would like to thank **Dr. C. Badarinath**, Head of department, Mechanical Engineering, The Oxford College of Engineering, for his continuous support and guidance. I am also grateful to **Dr. Rajendra Prasad**, Principal, The Oxford College of Engineering for providing the necessary facilities to carry out the project.

I would like to thank **Mohan Kumar.C.P** Head of Refrigeration section BAMUL Dairy Bangalore for his guidance and support.

I would also like to thank **Harish H.V**, Asst. Prof. Nitte Meenakshi College of Engineering for taking his precious time out to guide me in every step of the project.

REFERENCES

1. Amit prakash "IMPROVING THE PERFORMANCE OF VAPOUR COMPRESSION REFRIGERATION SYSTEM BY USING SUBCOOLING AND DIFFUSER" IJEBEA 13-129 2013
2. R. Rejikumar et.al "HEAT TRANSFER ENHANCEMENT IN DOMESTIC REFRIGERATOR USING R600a/mineral oil/ nano-AL₂O₃ AS WORKING FLUID" IJECR APRIL 2013 VOL 03, ISSUE 04.
3. M. Krishna Prasanna M.E. student, and P.S Kishore "ENHANCEMENT OF COP IN VAPOUR COMPRESSION REFRIGERATION SYSTEM" IJERT NOV 2014 VOL 3, ISSUE 11.
4. R.T.Saudagar and Dr.U.S.Wankhede "VAPOUR COMPRESSION REFRIGERATION SYSTEM WITH DIFFUSER AT COMPRESSOR INLET" IJERD JULY 2012 VOL1, ISSUE 11